

Optical imaging by means two-photon quantum entanglement (ghost imaging)

Optical imaging by means of two-photon quantum entanglement

T. B. Pittman, Y. H. Shih, D. V. Strekalov, and A. V. Sergienko

Department of Physics, University of Maryland Baltimore County, Baltimore, Maryland 21228

(Received 22 December 1994)

A two-photon optical imaging experiment was performed based on the quantum nature of the *signal* and *idler* photon pairs produced in spontaneous parametric down-conversion. An aperture placed in front of a fixed detector is illuminated by the *signal* beam through a convex lens. A sharp magnified image of the aperture is found in the coincidence counting rate when a mobile detector is scanned in the transverse plane of the *idler* beam at a specific distance in relation to the lens.

PACS number(s): 42.50.Dv, 03.65.Bz

entanglement

One of the most surprising consequences of quantum mechanics is the entanglement of two or more distant particles.

The classic example of a two-particle entangled state was given by Einstein, Podolsky, and Rosen (EPR) in their famous 1935 gedanken experiment.

EPR : two particle state where the position of each particle is undetermined, but the measurement of one particle at a certain location implies that the other must be found at a specific corresponding location. Furthermore, a similar argument holds in momentum space.

entanglement

A typical example of an entangled state is the two photon state generated from spontaneous parametric down-conversion (SPDC).

Infinite number of ways the down-converted photon pairs can satisfy the phase-matching conditions.

Experiment setup

schematic

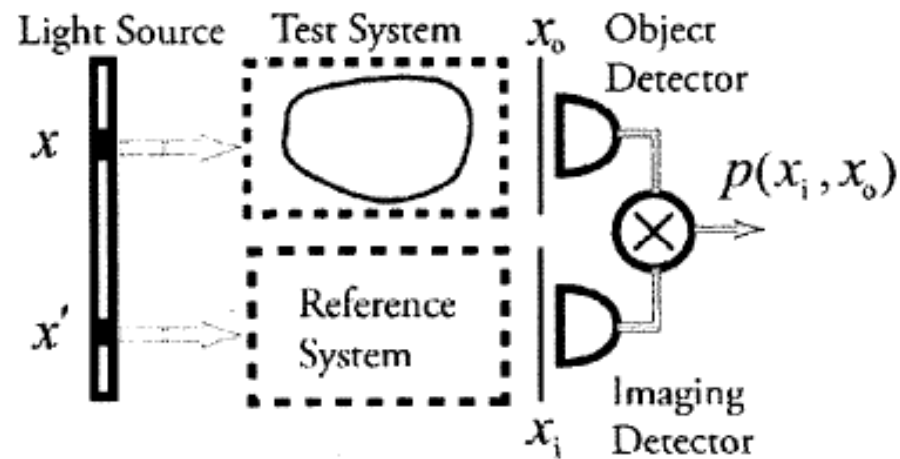

The transfer function of the test system is to be obtained from the joint detection statistic using knowledge of the reference system.

Experimental setup

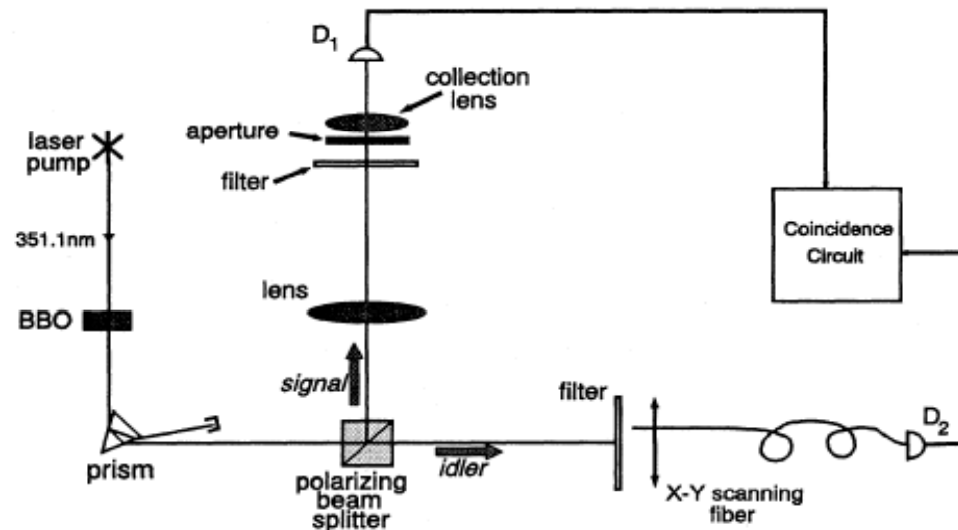

pump beam : 351.1nm argon ion laser

nonlinear BBO crystal that is cut at a degenerate type-II phase-matching angle to produce pairs of orthogonally polarized signal (e-ray) and idler (o-ray) photon. The pairs emerge from the crystal nearly collinearly, with $\omega_s = \omega_i = \omega_p/2$.

fused silica dispersion prism and the remaining signal and idler beams are sent in different directions by a polarization beam-splitting Thompson prism.

signal beam → convex lens with a 400-mm focal length → (UMBC) aperture → 702.2nm bandwidth 83-nm spectral filters → 25mm focal length collection lens → 0.8mm diam dry ice cooled avalanche photodiode.

idler beam → 702.2nm bandwidth 83-nm spectral filters → 0.5mm diam multimode fiber → another dry ice cooled avalanche photodiode.

Experiment

By recording the coincidence counts as a function of the fiber tips's transverse plane coordinates in the idler beam, we see the image of the UMBC aperture. (aperture 3.5X7 mm observed image measures 7X14 mm)

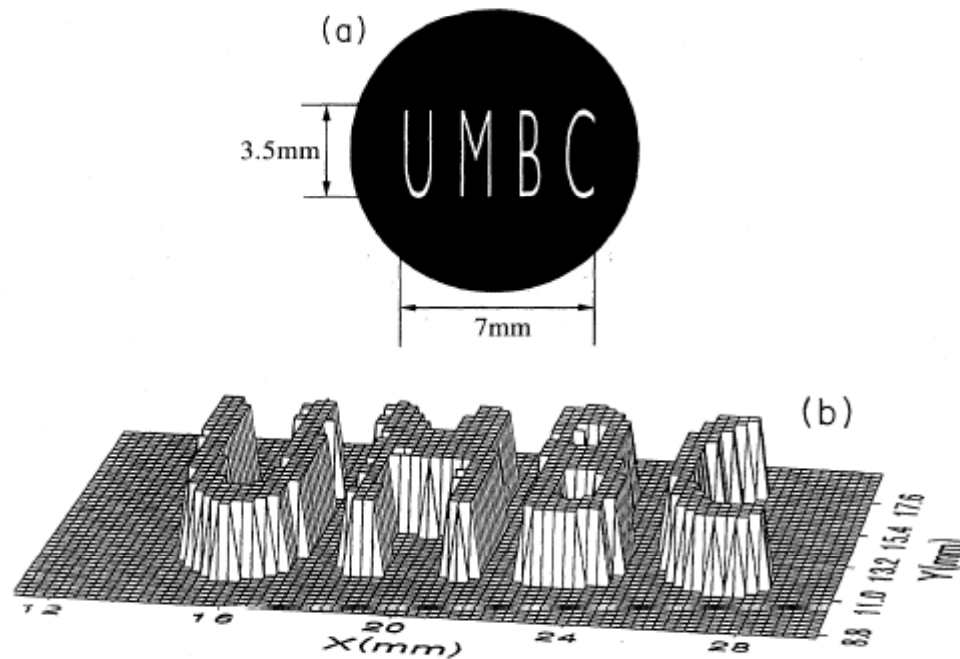

FIG. 2. (a) Reproduction of the actual aperture placed in the signal beam. Note that the size of the letters is on the order of standard text. (b) Coincidence counts as a function of the fiber tip's transverse plane coordinates. The scanning step size is 0.25 mm. The data shown is a "slice" at the half maximum value, with no image enhancement.

Experiment

Gaussian thin lens equation

$$1/S + 1/S' = 1/f$$

focal length of the lens f , the aperture's distance along the optical path from the lens S , and the image plane's (fiber tip plane) optical distance from the lens S' .

In this experiment chose $S=600$ mm , and the twice magnified clear image was found when the fiber tip was in the plane with $S'=1200$ mm

Experiment

Phase-matching conditions $k_s + k_i = k_p$

Transverse components of the wave vector condition

$$k_s \sin \alpha_s = k_i \sin \alpha_i$$

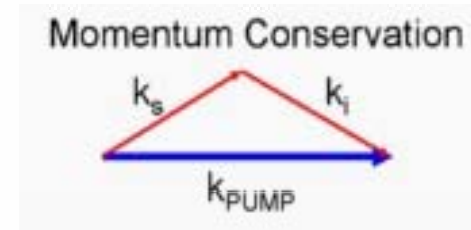

α_s, α_i are the scattering angles of the signal and idler photon relative to the pump beam inside the crystal.

Upon exiting the crystal, Snell's law thus provides

$$\omega_s \sin \beta_s = \omega_i \sin \beta_i$$

β_s, β_i are the exit angles of the signal and idler photons with respect to the k_p direction.

Experiment

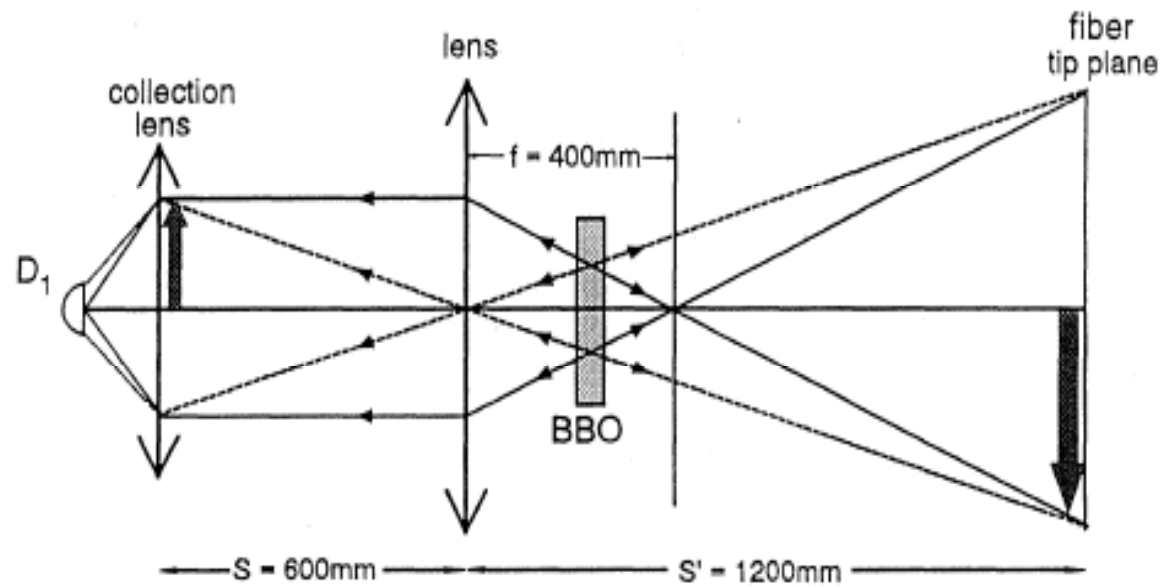

conclusion

Whereas the classical theory of imaging is very well established, and indeed it is possible to imagine some type of classical source that could partially emulate this behavior we have successfully performed optical imaging by means of a quantum-mechanical entangled source. By taking advantage of the two-photon state generated in SPDC, the use of a lens in the signal beam has established an image plane with the definitive point by point correspondence to the object(i.e. aperture) plane. The entanglement of this two-photon state is analogous to that discussed by EPR and can be used to demonstrate high resolution imaging that can be interpreted through a “two-photon Gaussian thin lens equation.”